

INSTRUCTIONS

REESE 5TH WHEEL HITCH MOUNTING ADAPTER KIT FOR CHRYSLER UNDERBED MOUNTING SYSTEM #30154 SAE J2638 RATED TO 25,000LB GROSS TRAILER WIEGHT

DEALER/INSTALLER:

1. Provide this Manual to end user.
2. Physically demonstrate mounting and un-mounting procedures in this Manual to end user.
3. Have end user demonstrate that he/she understands procedures.

END USER:

1. Read and follow this Manual every time you use adapter.
2. Save this Manual for future reference.
3. Pass on this manual to any other user or owner of adapter.
4. Never remove adapter warning decals . If damaged, contact Cequent Performance Products, Inc. (1-888-521-0510) for free replacement.

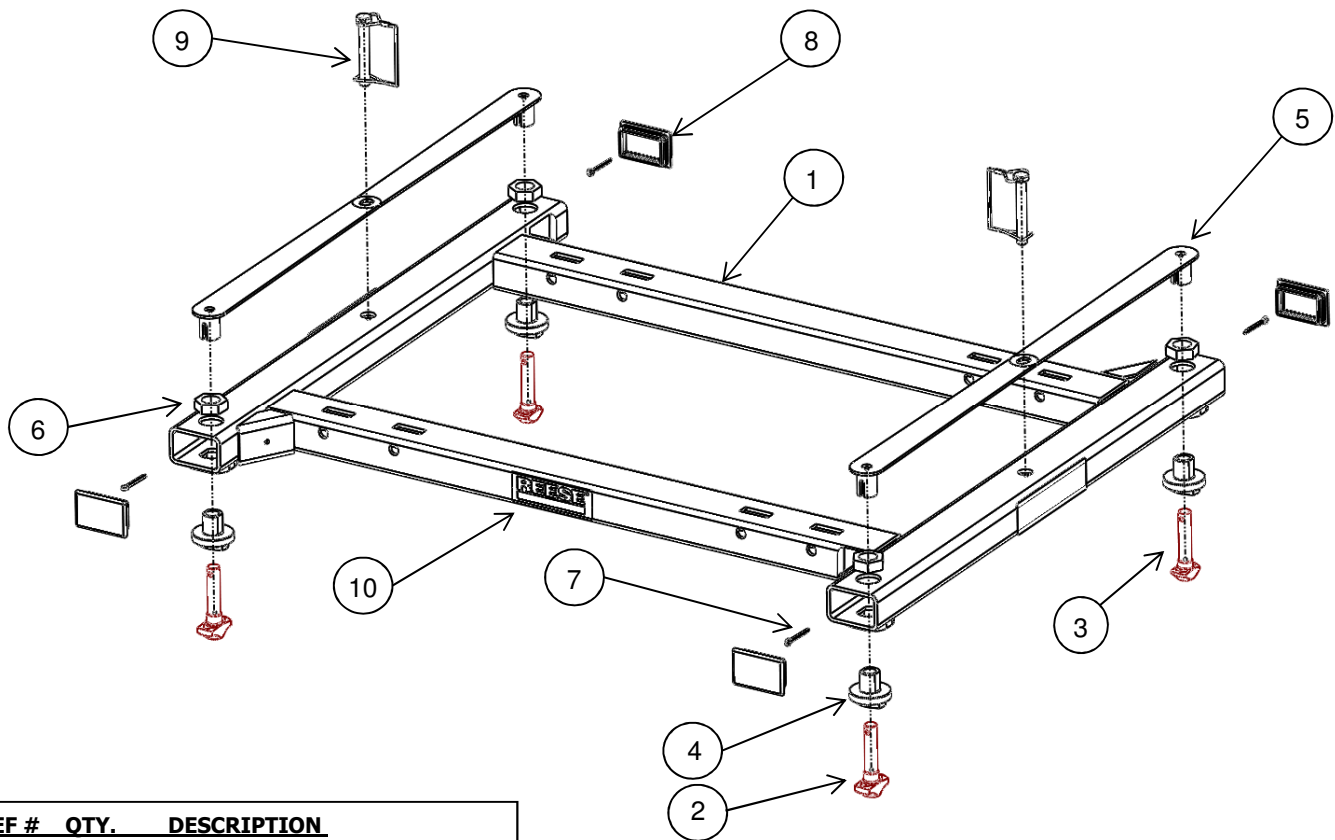

REF #	QTY.	DESCRIPTION
1	(1)	ADAPTER WELDMENT
2	(2)	REAR HD TEE-PIN ANCHOR
3	(2)	FRONT TEE-PIN ANCHOR
4	(4)	ANCHOR BUSHING
5	(4)	ANCHOR HANDLE
6	(4)	1" JAM NUT
7	(4)	COTTER PIN
8	(4)	END CAP
9	(2)	BAIL PIN
10	(1)	REAR FACING REESE LABEL



If this adapter used to tow anything over 20,000lbs it is REQUIRED that the included Heavy Duty bolts are used instead of the standard attachment pins and spring clips

For Installation Assistance or Technical Help, Call 1-888-521-0510

⚠ WARNING:

Failure to follow all of these instructions may result in death or serious injury

INDEX

1. SYSTEM ASSEMBLY	P. 2	2. SYSTEM ADJUSTMENT	P. 3
3. INSTALLATION	P. 4	4. REMOVAL	P. 4
5. BEFORE EACH TRIP/LUBRICATION	P. 4	6. LIMITED LIFETIME WARRANTY	P. 5

SYSTEM ASSEMBLY

REQUIRED TOOLS

- 1 1/2" CLOSED END WRENCH
- NEEDLE NOSE PLYERS
- RUBBER MALLET

TEE PIN AND BUSHING ASSEMBLY

The anchor bushing is passed through the fore-aft tube, aligning the flat edge in the tube with the flats in the bushing. Then the 1" jam nut is threaded on to the anchor bushing to a point where there is no more vertical motion allowable and then another quarter turn of the nut. The Tee pin anchor is then passed through the anchor bushing and the anchor handle is threaded on to the tee pin.

It is important to note both larger, Heave Duty tee pins are in the rear of the adapter, the rear of the adapter has a REESE label facing outward.

Once the tee pin anchor is set at the correct height a cotter pin is passed through the slot in the anchor handle and the hole in the tee pin anchor. Finally the end cap is installed with the ribs being inserted into the fore-aft tube.

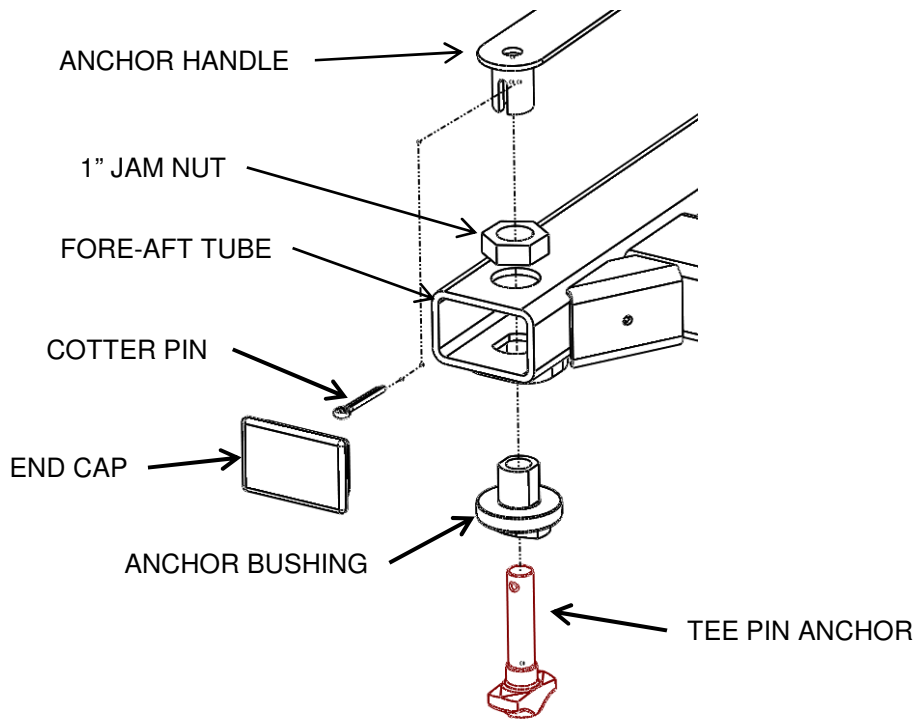
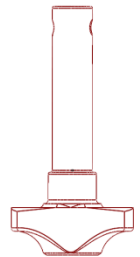
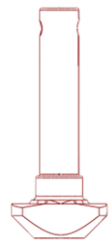

FIG 1



**FIG 2a
HD TEE PIN ANCHOR
(MATCHING SCALE)**



**FIG 2b
TEE PIN ANCHOR
(MATCHING SCALE)**

REESE Fifth Wheel Mounting Adapter Adjustment

The REESE mounting kit adapter is pre-assembled to fit the average truck, however each truck is different. Thus, possible adjustment might be required before the kit will work best.

- Place unit into pucks with all handles in unlocked position (see Figure 3a). Rotate handles into locked position. It is normal for some of the handles to have less resistance than others, however if all four handles are in the locked position and there is still excessive vertical play in the kit the tee pin anchors need to be adjusted. Should a handle not be able to be locked by hand; it needs to be adjusted.
- If the adapter does not fall into the under bed mounting pucks, when handles are in unlocked position, the tee pin bushing needs adjustment. This can be done by loosening removing the four cotter pins in the anchor handles, then unthreading the tee pins from the anchor handles. Once the handles and tee pins are removed a closed ended wrench can be used to loosen the four 1" jam nuts (refer to fig 1). Do not completely unthread the jam nuts, then drop the kit into the mounting pucks. While the kit is in the correct position tighten down the 4 jam nuts so there is not vertical play in the anchor bushing and the fore-aft tube. Finally install the tee pins and the cotter pins in the reverse order they were removed, or follow the system assembly (page 2) . Replace the plastic end caps.
- To adjust handle tension when locked; first remove adapter from pucks. Next, while keeping the handle to tee pin orientation, remove the cotter pin. To loosen, rotate the tee pin counterclockwise ½ rotation, and replace cotter pin. Conversely, if there is too much clearance in the attachments when locked, the clearance can be removed by rotating the tee pin clockwise ½ rotation, and replacing the cotter pin. If adapter still will not securely pin into under bed mounting kit, or is still too loose, steps may need to be repeated.

Figure 3a. Anchor handles in unlocked position

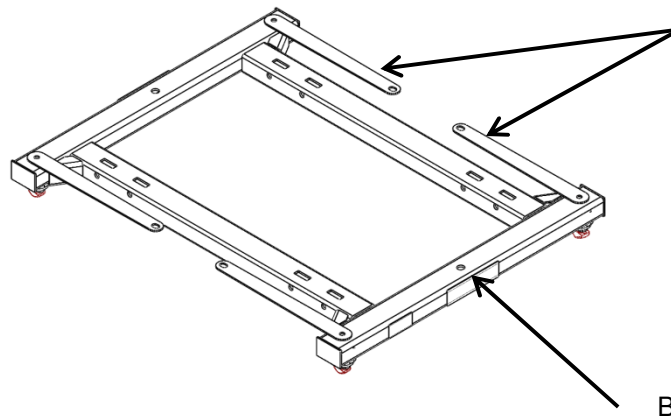
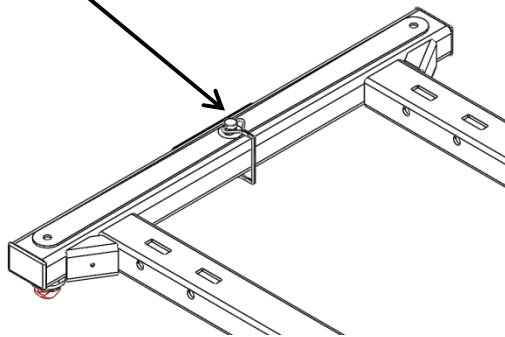

Figure 3b. Anchor handles in locked position (overlapped), with Bail Pin locked in place



Puck Plug

Truck Bed

Puck

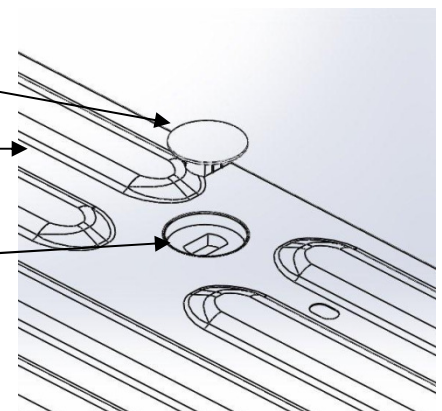

Figure 4: Puck Plugs



WARNING:

Failure to properly install and pin handles could result in tow vehicle damage or truck and trailer separation.

ADAPTER INSTALLATION:

1. Remove puck plugs from all (4) of the pucks in the truck bed (Figure 4) and store for use when adapter is removed.
2. Set REESE mounting adapter onto the pucks, and rotate handles into unlocked position (approximately parallel with the cross tube, (Figure 3a) until adapter drops into pucks on all (4) corners.
3. Rotate (4) handles into locked position, with holes in the anchor handles coincidental with the hole in the fore-aft tube (Fig 3b).
4. Place bail pins / locks through the overlapping handle holes on each side to anchor hitch into pucks (Figure 3b).
5. Use industry standard attachment pins to secure fifth wheel to adapter.

NOTE: If a trailer larger than 20,000 lbs is going to be towed with this adapter it is REQUIRED that the included Heavy Duty attachment bolts are used in place of the standard attachment pins.

ADAPTER REMOVAL

1. Remove bail pin / lock from the overlapping handle holes on each side of the adapter (Figure 3b). Store bail pins.
2. Rotate (4) handles into unlocked position (parallel with cross tube, Figure 3a). Lift each side of adapter out of pucks separately, handles may have to be worked slightly to align anchors with puck holes to remove.
3. Store adapter in dry place where dirt and debris will not get into anchor assemblies.
4. Press puck plugs (packed with mounting kit) into all (4) of the pucks in the truck bed to keep debris out of pucks (Figure 4).

BEFORE EACH TRIP

1. Lube feet with lithium grease for easier engagement as shown in Figure 6
2. Before each trip or maneuver, check to make sure both the Tee pin arms as well as the pull pin (included in fifth wheel hitch hardware bag) are in place and have respective lynch pins locked in place.
3. Review operation manuals for both the fifth wheel hitch being used, and the corresponding Elite or Signature Series mounting kit being used.

Figure 5

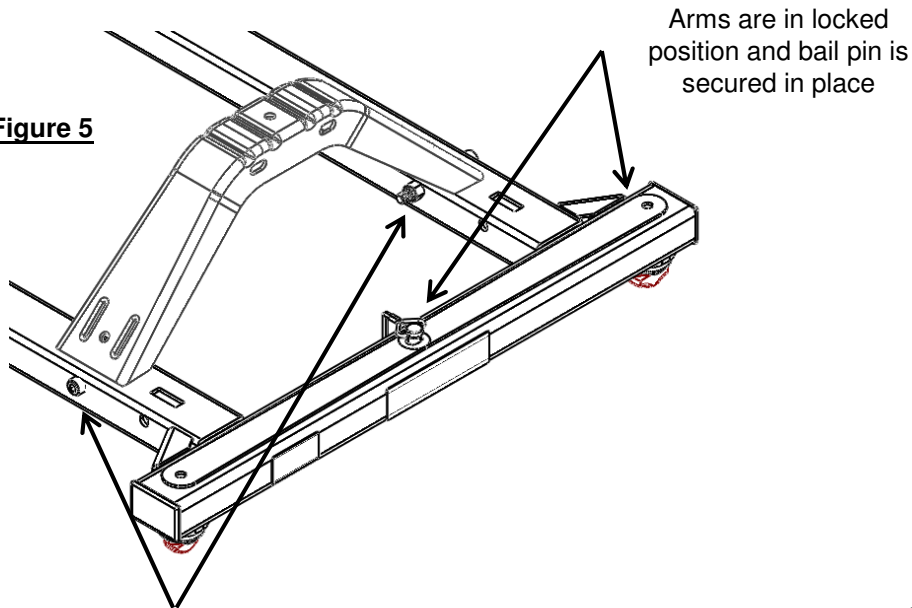

Pull pins have been replaced with Heavy Duty attachment bolts, locking arches and adapter together. Included nylon lock nut needs to be threaded until it contacts the cross tube and there is minimum gap between cross tube and bolt head.

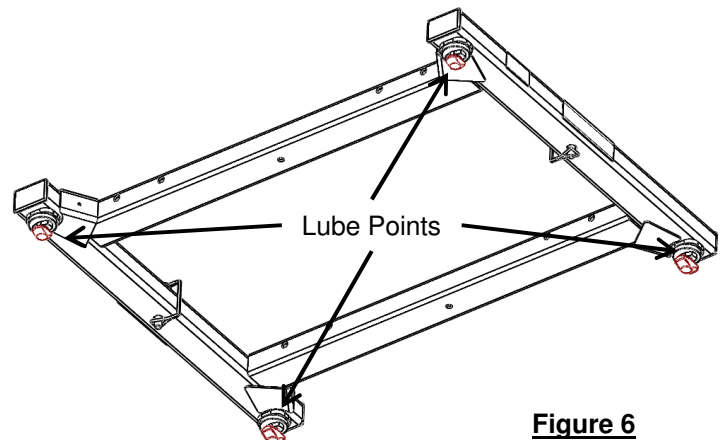

Figure 6

NOTES

LIMITED LIFETIME WARRANTY

Part No: _____

Date of Original Purchase: _____

Original Owner: _____

Original Installer: _____

1. Limited Lifetime Warranty ("Warranty"). Cequent Performance Products, Inc. ("We" or "Us") warrants to the original consumer purchaser only ("You") that the product will be free from material defects in both material and workmanship, ordinary wear and tear excepted; provided that installation and use of the product is in accordance with product instructions. There are no other warranties, express or implied, including the warranty of merchantability or fitness for a particular purpose. This warranty is not transferable.
2. Limitations on the Warranty. This Warranty does not cover: (a) normal wear and tear; (b) damage through abuse, neglect, misuse, or as a result of any accident or in any other manner; (c) damage from misapplication, overloading, or improper installation; (d) improper maintenance and repair; and (e) product alteration in any manner by anyone other than Us, with the sole exception of alterations made pursuant to product instructions and in a workmanlike manner.
3. Obligations of Purchaser. To make a Warranty claim, contact Us, at our principal address of 47912 Halyard Dr. Suite 100, Plymouth, MI 48170, 1-888-521-0510, identify the product by model number, and follow the claim instructions that will be provided. Any returned product that is replaced by Us becomes our property. You will be responsible for return shipping costs. Please retain your purchase receipt to verify date of purchase and that You are the original consumer purchaser. The product and the purchase receipt must be provided to Us in order to process Your Warranty claim.
4. Remedy Limits. Product replacement is Your sole remedy under this Warranty. We shall not be liable for service or labor charges incurred in removing or replacing a product or any incidental or consequential damages of any kind.
5. Assumption of Risk. You acknowledge and agree that any use of the product for any purpose other than the specified use(s) stated in the product instructions is at Your own risk.
6. Governing Law. This Warranty gives You specific legal rights, and You also may have other rights which vary from state to state. This Warranty is governed by the laws of the State of Michigan, without regard to rules pertaining to conflicts of law. The state courts located in Oakland County, Michigan shall have exclusive jurisdiction for any disputes relating to this Warranty.

Cequent Performance Products, Inc.
47912 Halyard Dr. Suite 100
Plymouth, MI 48170